



*DuraBrite Pro Series* is a flagship model designed by a team of military and aerospace electronics product engineers who refuse to compromise.

The *Pro* uses state-of-the-art LED chip technology, high reliability control and low draw circuitry, and a patented thermal dissipation architecture (US Patent# 9,648,750), all housed in a sleek yet rugged package that pushes the lumens-to-weight ratio boundary to the extreme. Unique in the Durabrite product family, every *Pro* is treated with our very own *Ceramax Ultra Coat* so they stay looking new for many years to come.

Outputting a massive 50,000 lumens, the *Pro* draws a seemingly unachievable 18A at 24V, leaving the competition in the dust. The special optical form factor not only looks handsome on any professional vessel, it also yields top-notch real-world performance.

Unlike regular light bars, *The Pro* gives both extended range and coverage with its carefully chosen and field-tested beam angles so you can see and be seen with ease from a few miles out. It literally turns night into day and it's no wonder Durabrite owners call it the #electricsun.

Custom design variants are also available for industrial settings especially for use in extreme high heat high bay environment where most LED lighting products fail to survive and deliver.



US Patented Optics

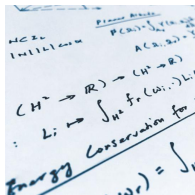

Light Shaping Technology

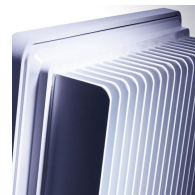

High Performance Materials



Advanced Venting System

Protected by:

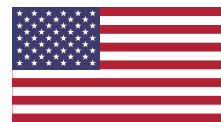

Designed & Assembled In USA

## Optical & Electrical Characteristics (All ratings are at 25°C unless otherwise specified)

---

LED Color, CCT	Typical = 5000K (Neutral white) 2800K option available as Special Order
Brightness, dimmable	50,000 lm at 24VDC & 32VDC 40,000 lm at 12VDC
Beam Angle	25 deg (Spot) 76 deg (Flood)
Operating Voltage	Auto detect 12VDC, 24VDC, 32VDC <small>*Most efficient to operate at 24VDC for max brightness</small>
Current Draw	Approx. 14A at 32VDC Approx. 18A at 24VDC Approx. 26A at 12VDC
Total Power Consumption	440W at 24VDC & 32VDC 304W at 12VDC

---

## Mechanical Qualifications

---

Water Resistance	IP68 <small>(submerged to 4.5 ft water for 30min)</small>
Moisture Resistance	65°C / 95% RH Mil-Std-883 TM 1004.7
Salt Spray / Corrosion Resistance	240 hrs @ 35°C ASTM B 117-09 /ASTM D1654-08
Temperature Range	-40°C to 55°C Mil-Std-883 TM1010.8
Mechanical Shock	30G, 11ms Half Sine, 3-axes (+ve/-ve) Mil-Std-202 TM213B
Vibration Resistance	100,000 cycles, 3-axes ANSI C136.31

---

## Warranty Terms

We stand behind our products. This product is covered by Durabrite's 5 Year Limited Warranty against material and manufacturing defects. However, it does not cover application and conditions that are outside of the product design parameters, abuse, and wear-and-tear. Further details can be found on our website at: <https://durabritelights.com/pages/warranty>

## Special Note on Bracket Installation & Corrosion Prevention

The bracket that comes with the Pro is laser cut with Marine Grade 316 Stainless Steel and is coated with Durabrite's **Ceramax Ultra Coat**. Even though it has superior corrosion resistance, and a 9H surface hardness, it does not mean it is corrosion proof. It can still rust if the ceramic coat barrier is broken and there is a buildup of salt on its surface over a prolonged period of time in a marine environment.

Care should be taken to prevent scratching at the mounting locations (e.g. by means of Nylon washers). You will notice a set of Nylon washers that are pre-installed in between the light and the bracket (one on each side). Make sure you keep them in place to minimize interaction and/or scratching between the two metals as you tighten and adjust the angle. The light body is made of aluminum and coated with a hard anodize, which by design, offers excellent protection. But if the bare metals come in contact due to scratching, galvanic corrosion will take place.

## A Note on Breaker

Use one breaker per light so there is no current sharing issue you have to possibly deal with. You should always budget at least 30% more than the rated current for your voltage, per light, to take into account startup surge. This will help prevent overheating and will prolong the life of your breaker. For instance, if you are running 24VDC, the rated current draw is 18A. You should size your breaker to at least 23A for best reliability and longevity.

## A Note on Cable Length

- If you operate at 12V, the current draw will be approximately 26A. The 6ft cable that comes out of the light (i.e. the pigtail) is AWG12 and if you also plan to use a AWG12, your extension **SHALL NOT** exceed 10ft.
- This is to minimize resistance, which can lower the voltage that goes into the light. If your light looks dim or if it flickers, the most likely cause is an insufficient cable gauge or the cable run is too long.
- If you plan to do a longer cable run, we recommend you to first run the pigtail to a waterproof junction box close to the light, and from there, run a AWG10 or AWG8 to your DC power source depending on the overall length (consult us if you have a run more than 30ft)
- If you are doing 24V, the light will draw roughly 18A. A AWG12 should suffice for up to a 30ft run.

Authorised Distributor



t: +44 1264 860 186

e: [spares@simplexturbulo.com](mailto:spares@simplexturbulo.com)



Simplex-Turbulo is part of the **SLX** GROUP



## Mechanical Dimensions & Weight:



Thickness = 3.59"

Weight: 32 pounds  
(w/ marine grade 316 SS bracket)

## Mounting Bracket – Marine Grade 316 Stainless Steel

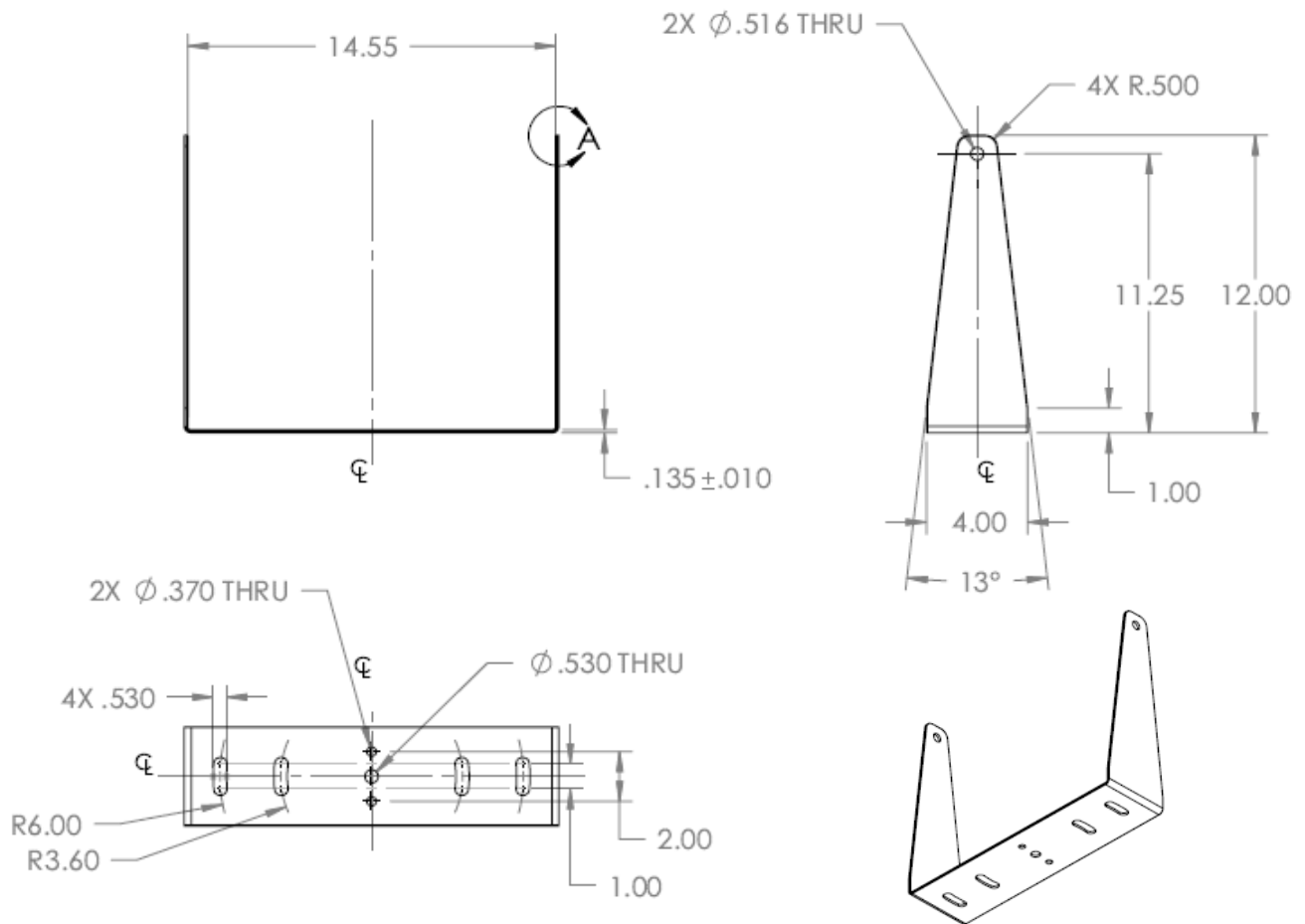

## IP67 Panel Mount Dimming Knob (Supplied upon request)

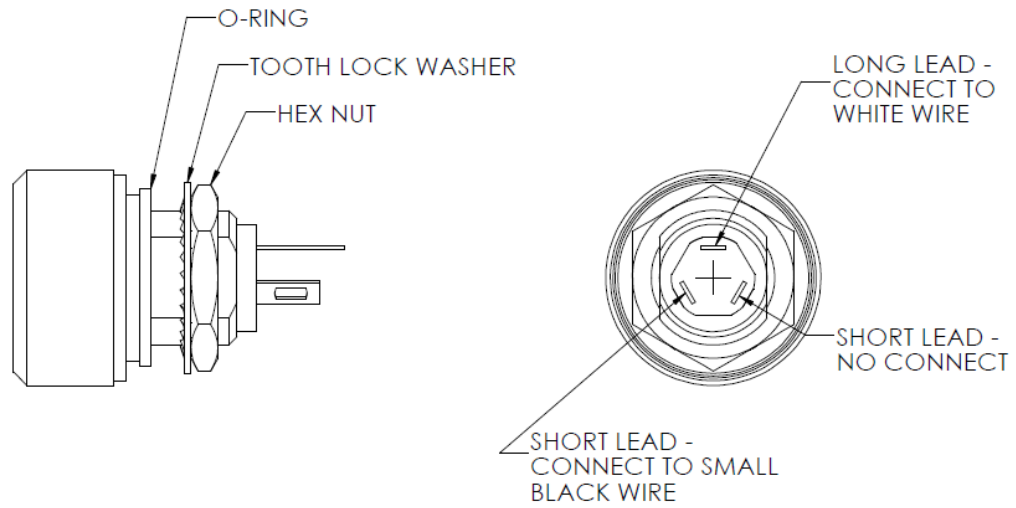

FOR NON-DIMMING OPERATION, LEAVE BOTH SMALL WIRES UNCONNECTED FOR MAX BRIGHTNESS