

FM200DS – 03 Centrifuge

Technical Data



BENEFITS

- Cleaner oil and extended oil life
- Lengthens service intervals
- Reduces engine wear
- Enhances long-term preventative maintenance
- Reduces maintenance costs
- Cuts waste disposal costs
- Reduces application down time
- Maximises in-service time for vehicle/engine /machine
- Reduces total cost of ownership
- Helps ensure clean combustion and fuel efficiency
- Supports engine technology for the reduction of exhaust emissions (e.g. exhaust gas recirculation)
- Centrifuge has been subjected to lifetime endurance testing for on engine applications*

DIMENSIONS (mm)

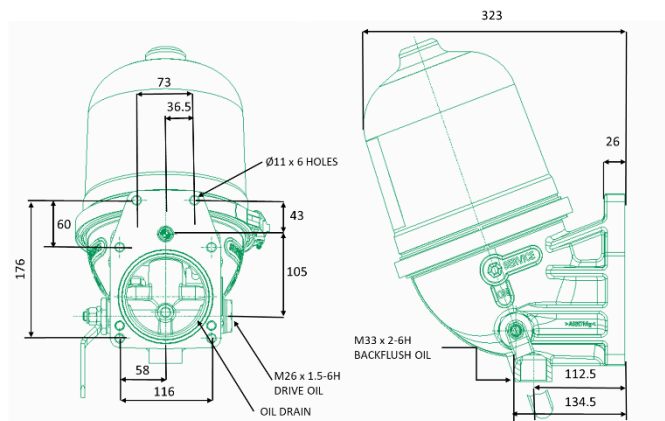

Model	FM200DS
Part number	
FM200DS-03	1439819S01
Drive Oil inlet thread	M26 x 1.5
Backflush Oil inlet thread	M33 x 2
Mounting holes size	Ø 11 mm
Net weight	13.2 Kg
Rotor dirt capacity	2 litres
Rotor oil capacity	2.3 litres

PERFORMANCE CURVES

Typical Rotor Performance for SAE 40 Oil @ 65 °C (FM200DS-03)

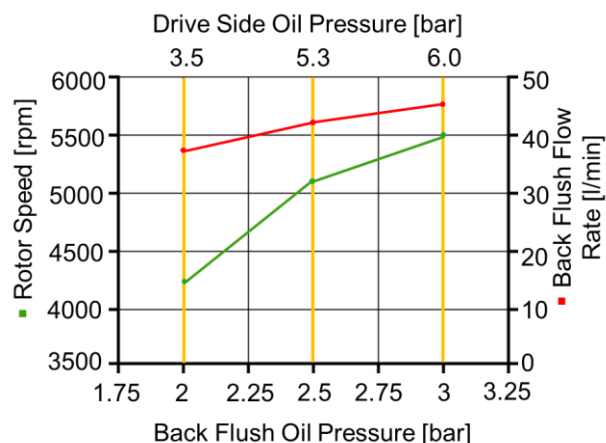

*Contact Mann+Hummel for further details

Authorised Distributor



t: +44 1264 860186

e: spares@simplexturbulo.com

STC is a member of

