

FM050P-LCB Centrifuge

Technical Data



BENEFITS

- Uses compressed air and a float valve assembly to forcibly return the cleaned oil to the engine sump
- Enables remote mounting with a small diameter return hose (e.g. on a vehicle chassis)
- Air consumption is almost nil, air flow to the sump being prevented by the float mechanism
- Prevents oil flow to the air system by a non-return valve
- Cleaner oil and extended oil life
- Lengthens service intervals and reduces application down time
- Reduces engine wear
- Enhances long-term preventative maintenance
- Reduces maintenance costs and total cost of ownership
- Cuts waste disposal costs
- Maximises in-service time for vehicle/engine/machine
- Helps ensure clean combustion and fuel efficiency
- Supports engine technology for the reduction of exhaust emissions (e.g. exhaust gas recirculation)

DIMENSIONS (mm)

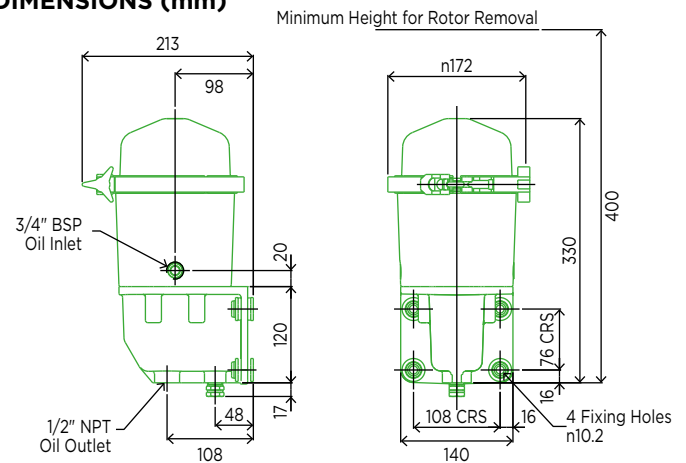

PERFORMANCE CURVES

Typical Rotor Performance for SAE 30 Oil @ 100°C

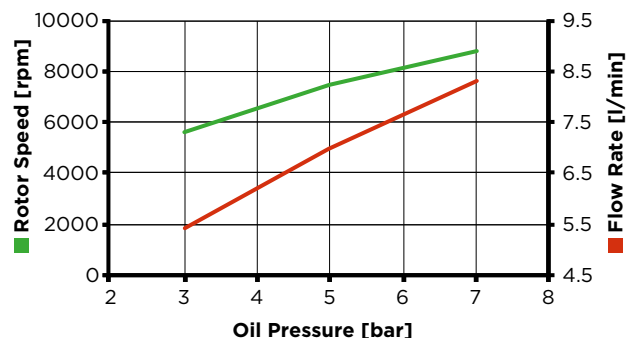

Model	FM050P-LCB
Part number	68 991 52 001
Oil connection	3/4 B.S.P.
Air connection	1/4" NPT
Cut Off Valve (C.O.V.) ratings	1.3 bar
Net weight	4.9 kg
System capacity	15-90 litres for lubrication systems
Filter dirt capacity	0.50 litres
Filter oil capacity	1.125 litres
Minimum oil feed pipe size	Ø 9.5 mm internal
Minimum oil drain pipe size	Ø 12 mm internal
Rotor	Plastic, disposable

Authorised Distributor



t: +44 1264 860 186
e: spares@simplexturbulo.com

Simplex-Turbulo is part of the **SLX** GROUP

Leadership in Filtration

