

DFBO Series

Duplex Fuel Filters
Max. 90 l/min. 10 bar



Continuous diesel filtration in Marine applications with DFBO duplex filter:

The new DFBO duplex filter brings Racor® FBO filters to engine room environment. The new duplex design ensures that fuel is efficiently filtered all the time. The cast iron head and steel bowls mean that it can be used in Marine applications.

The DFBO comes with two bowl lengths allowing diesel flows up to 90 l/min. Depending on the elements inside the unit can be used as a prefilter, a water separator/particle filter or a water absorptive filter. Easy service, no special tools are required.



Contact Information:

Parker Hannifin
Hydraulic Filter Division Europe

European Product
Information Centre
Freephone: 00800 27 27 5374
(from AT, BE, CH, CZ, DE, EE, ES,
FI, FR, IE, IT, PT, SE, SK, UK)
filtrationinfo@parker.com

www.parker.com/hfde

Applications:

- Fuel systems on diesel engines
- Marine fuel docks
- Diesel fuel dispensing system



Specification

Duplex filter:

Change-over valve with open center position. Locking device for both end positions and center position. Manual vent valves and drain valves.

Maximum operating pressure:

10 bar (Marine assemblies 7 bar)

Connections:

Threaded ports M30 x 1,5 or optionally G1" facing downwards.

Seal material:

Fluoroelastomer

Operating temperature:

0°C...+80°C (Marine assemblies 0°C...+60°C), for other temperatures consult Parker Filtration.

Housing material:

Head material cast iron, bowl material steel.

Weight:

40 kg

Nominal flow rate (3 cSt):

DFBO-10: 70 l/min (4.2 m³/h)

DFBO-14: 90 l/min (5.4 m³/h)

Bypass valve:

No bypass

Filter elements:

Filter separator elements with micron ratings 10 µm and 25 µm remove water and contaminants from fuel streams. Other types of FBO elements and other ratings are available, see replacement element table on the following page.

Fluid compatibility:

Suitable for use with diesel fuel, jet fuel, gasoline, kerosene, JP4, JP5 and JP8.

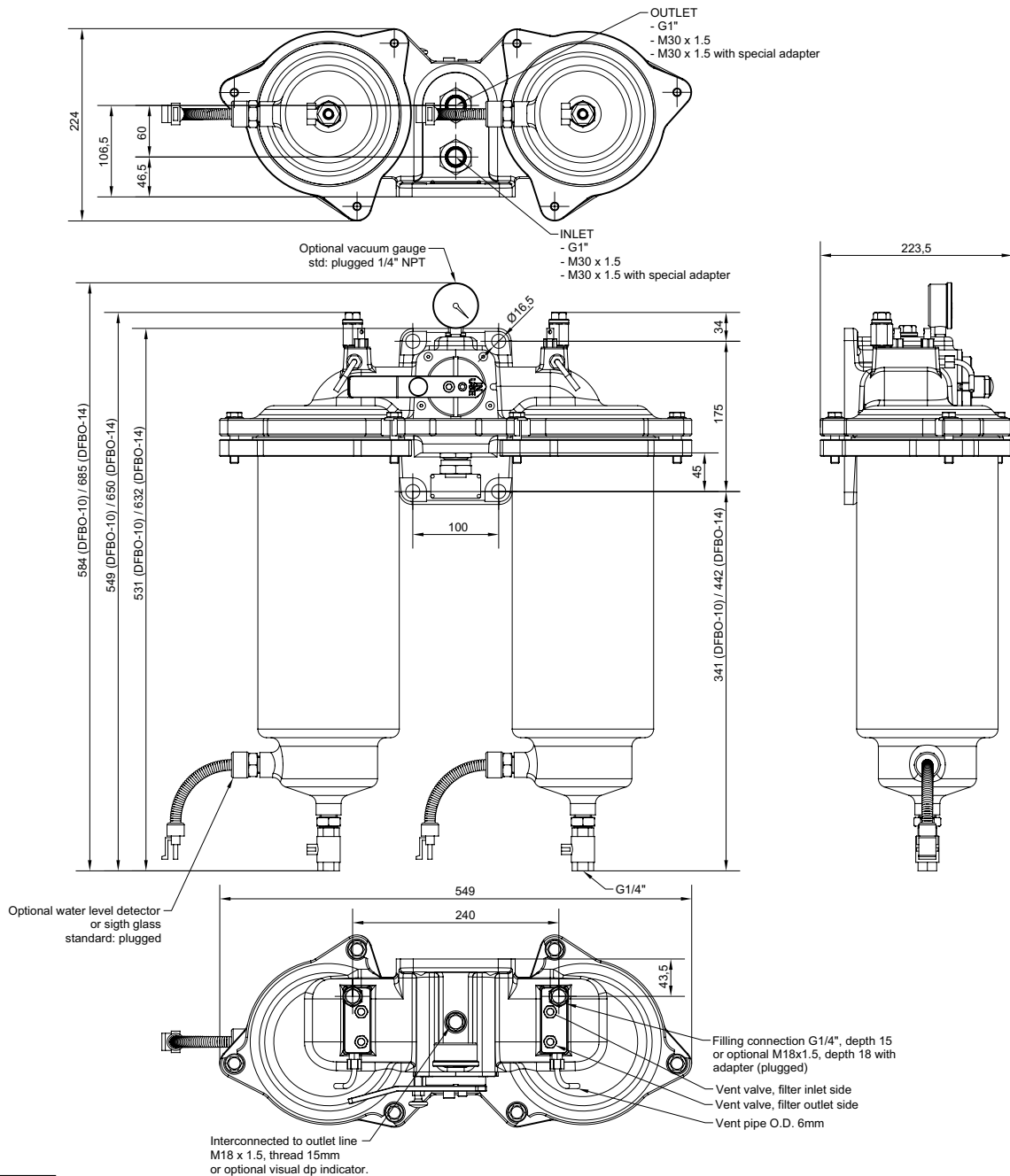

Product Description for DFBO

Complete Filter:

Table 1	Table 2	Table 3	Table 4	Table 5	Table 6	Table 7	Table 8
---------	---------	---------	---------	---------	---------	---------	---------

Table 1

FILTER TYPE	
Model	CODE
Duplex filter	DFBO

Table 2

FILTER SIZE	
Element length	CODE
Length 10"	10
Length 14"	14

Table 3

MICRON RATING	
Filter separator element	CODE
Rating 10 µm	10FS
Rating 25 µm	25FS
Without elements	XXX

Table 4

SEAL TYPE	
Seal material	CODE
Fluoroelastomer	V

Table 5

INDICATORS	
Options	CODE
Indicator port plugged	P
Vacuum gauge in outlet side	A

Table 6

INDICATOR SETTING	
Options	CODE
No indicator	X
1,0 bar (15 psi)	F

Table 7

FILTER CONNECTIONS	
Port size	CODE
M30 x 1,5 connections down	MD30
G1" - connections down	GD16

Table 8

OPTIONS	
Options	CODE
Standard	1
Sight level glass in bowl	SG
Water level probe in bowl	WP
Marine assembly (max 7 bar)	MA

Max flow rate [l/min] with marine diesel oil at 3 cSt	One side in use		Both sides in use	
	10 micron	25 micron	10 micron	25 micron
DFBO-10	10FS	25FS	10FS	25FS
Vacuum side	45	45	60	60
Pressure side	70	70	100	100
DFBO-14	10FS	25FS	10FS	25FS
Vacuum side	60	60	80	80
Pressure side	90	90	130	130

All FBO elements fit in DFBO filter. Check the suitable replacement element from this table.

Element	Micron	Filter Separator	Pre-Filter	Water Absorber
FBO-10	1	FBO 60327	FBO 60330	FBO 60333
	5	FBO 60328	FBO 60331	FBO 60334
	10	FBO 60353	FBO 60354	FBO 60355
	25	FBO 60329	FBO 60332	FBO 60335
FBO-14	1	FBO 60336	FBO 60339	FBO 60342
	5	FBO 60337	FBO 60340	FBO 60343
	10	FBO 60356	FBO 60357	FBO 60358
	25	FBO 60338	FBO 60341	FBO 60344



Authorised Distributor



t: +44 1264 860186
e: spares@simplexturbulo.com



STC is a member of SIMPLEX ENGINEERING GROUP