

Simplex Bush in bush system

General description

- Bush in bush version with sterntube bush in assembly bush
 - Assembly bush: inside finish-machined and outside rough-machined with seal flange ring
 - Inlay bush: inside and outside finish-machined for easy exchange
- True customized turnkey solution ready for installation
 - for all vessel sizes
 - for all vessel types
- Certified by all major classification societies

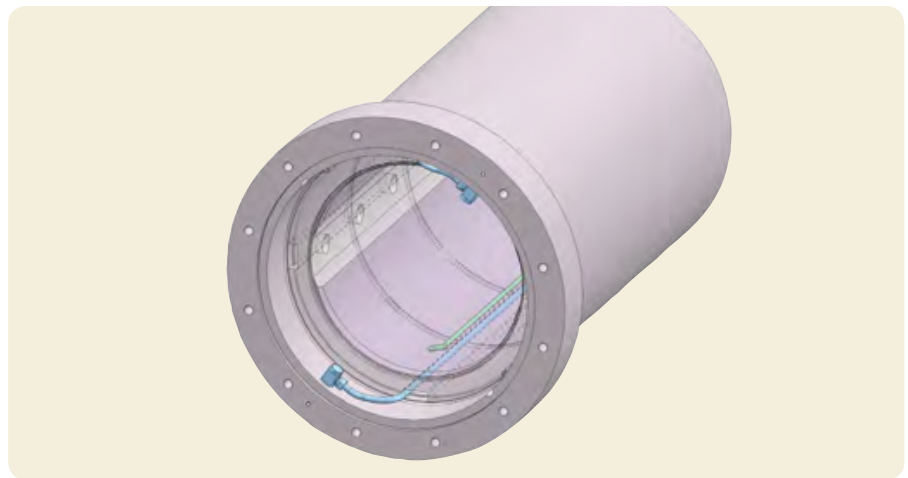

Advantages

Design

Customised and tailor-made to meet new building demands

Designed with all necessary pipes for seals, temperature sensor and hydrostatic connection

Computer-calculated hydrodynamic operational reliability to determine various technical parameters:

- Shaft diameter
- Maximum and minimum rpm
- Radial load in t or kN
- Maximum ambient and sea water temperatures
- Oil viscosity (if oil type is known)

A significant amount of work already done → less preparation work necessary for design office and shipyard

Complete system designed for Simplex seals → maximum reliability

Installation

Plug and play solution delivered fully assembled and tested → immediate and easy installation by the shipyard

Ultrasonically tested before shipment. Test certificate can be supplied on request

Operation

Stress-free installation → reduced transmission of resonance and vibration

Flexible Pt 100 temperature sensor (optional) for an in-situ replacement during opera-

tion of the vessel → no second sensor necessary as mandated by most classes

Services

Easy maintenance:

- Replaceable bushes of reliable Simplex-type
- Temperature sensors can be changed without shaft withdrawal

Designed for in-situ overhaul as per certified and approved Simplex repair standards

Worldwide service network and availability of spares

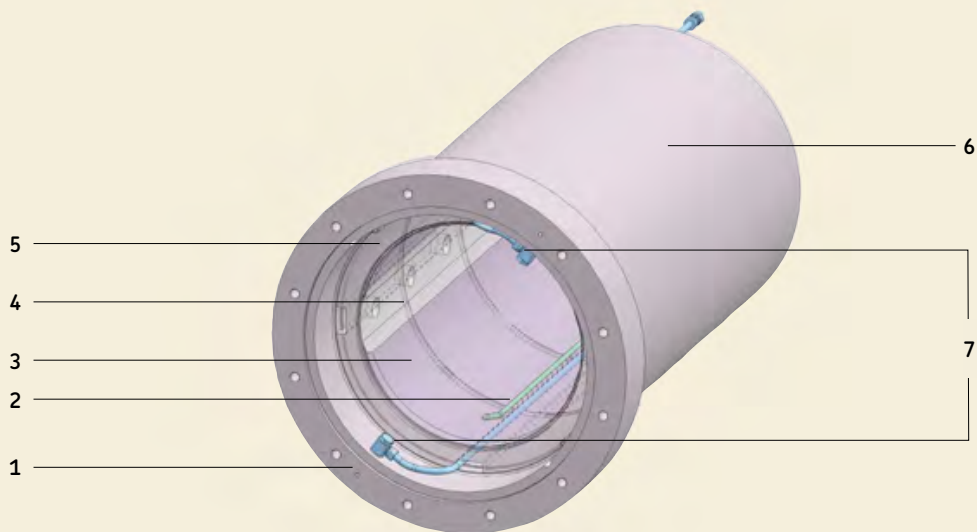

- 1 **Adapter rings (fwd and aft)** – For a precise seal connection
 - 2 **Flexible temperature sensors (Pt 100)** – Measurement of temperature at the white metal for remote monitoring
 - 3 **Lead or tin-based white metal lining** – Mainly for merchant shipping
 - 4 **Oil grooves straight-aligned** – Constant and reliable lube oil supply
Specific helical oil grooves – For twin-screw vessels
 - 5 **Material bush design EN-GJL-200 (GG-20) cast iron** – Mainly for merchant shipping
Material bush design EN-GJS-400-15 (GGG-40) spheroidal cast iron – For higher stresses
 - 6 **Final fixing of the complete bush in bush system with epoxy resin**
 - 7 **Supply lines – Air and oil supply for the aft seal, stern tube drain and lubrication**
-
- **Self-lubrication** – Lube oil supply by natural circulation
 - **Hydrostatic lubrication** – Including lubrication unit with temperature and pressure sensors – Minimized wear during manoeuvring with reversed direction of shaft rotation
 - **Direct forced lubrication** – Additional constant supply of fresh lubricant

Standard

-
-
-
-
-
-
-
-

Optional

-
-
-
-

Authorised Distributor



t: +44 1264 860186

e: spares@simplexturbulo.com

STC is a member of



© SKF is a registered trademark of the SKF Group.

© SKF Group 2015

The contents of this publication are the copyright of the publisher and may not be reproduced (even extracts) unless prior written permission is granted. Every care has been taken to ensure the accuracy of the information contained in this publication but no liability can be accepted for any loss or damage whether direct, indirect or consequential arising out of the use of the information contained herein.

PUB 43/P2 14867/1 EN · September 2015

